

Date 2023/12/9

Condition Carpet Asphalt

Track Situation Flat Bump

Track Course OHMツインサーキット

Traction High Medium Low

Track Size Small Medium Large X-Large

Driver Takashi Kato

Temperature Humidity

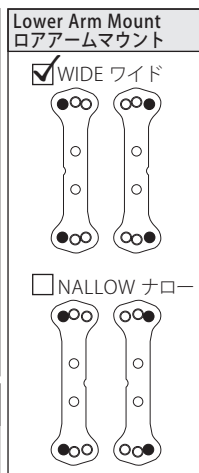
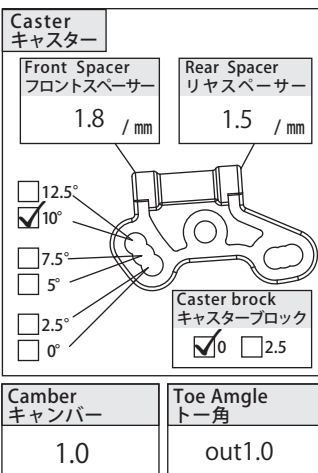
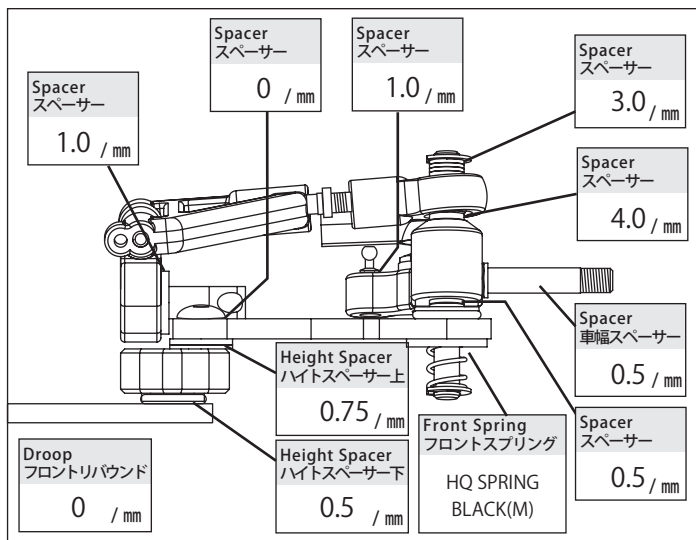

- Kingpin Oil HQ KINGPIN OIL SOFT
- Upper Arm AK12X
- Upper Arm Block AK12X
- Lower Arm AK12X
- Steering Block アルミ製 (AL.knuckle) TB20411

Front Arm Support Plate No Yes /mm

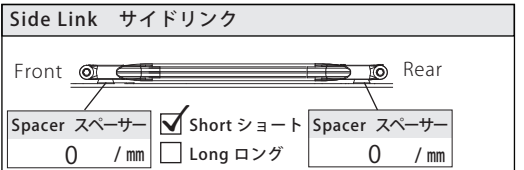
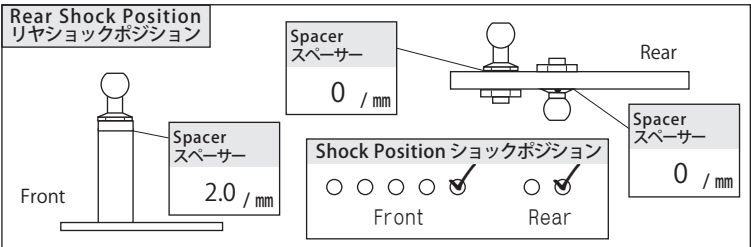
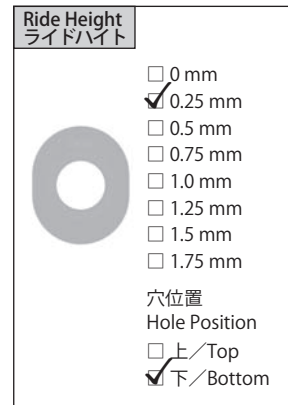
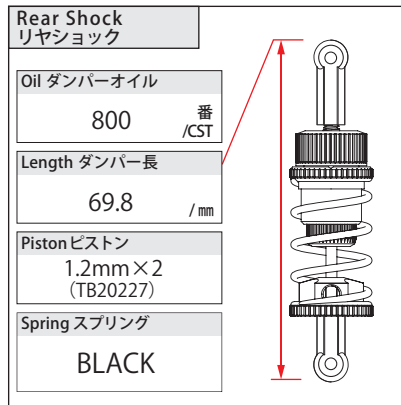

- Diff Setting Solid
- Carbon
- Steel
- Ball Diff

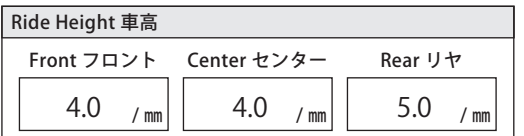
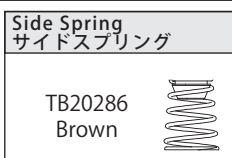
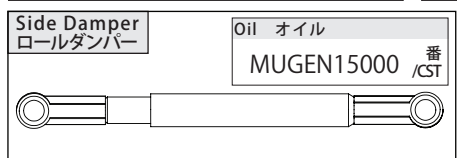

- Motor HW G3R 21.5 / 40度
- Spur Gear 76 / 40
- Battery G★STYLE 4200HV
- Electric Speed Controller HW
- Body TeamBomber LMP-KETTER (0.4 mm) 39 mm
- Body Mount Position

- Transmitter SANWA M17
- Receiver RX-493
- Servo SANWA PGS-HR (Type3)
- Servohorn XRAY
- Main Chassis AK12X (Aluminum)
- Lower Brace AK12X (Aluminum)
- Back Plate TB20205 (SOFT)

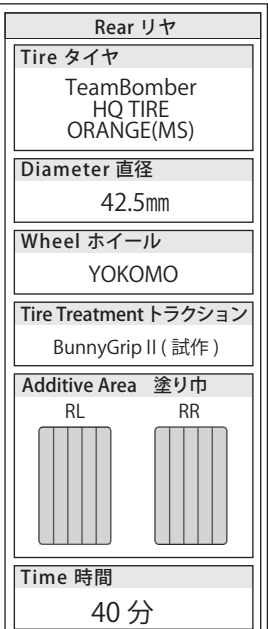
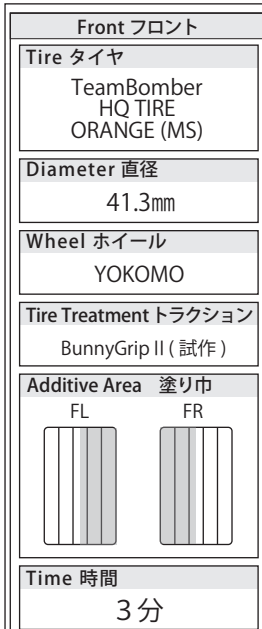
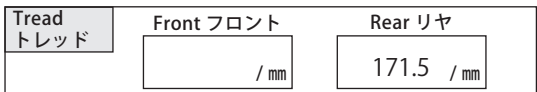

MEMO TB20230 チタンコートダンパーシャフト
 TB20264S フロントサスマウントプレート (S)
 TB20265 アルミ製リヤホイールビス
 TB20266 AK12 キャスターブロックサポート
 TB20267A 3D ボディバンパー V2
 TB20268 HQ フロントスプリングリテーナー

※SQUARE 製チタンビス使用

Ver1.0